

Honeywell | Gas Detection

E³Point[®] Gas Monitor

Standalone, Network, & Remote models







User Manual

1998M0972 Rev 01

Symbol Definitions

The following table lists the symbols used in this document to denote certain conditions:

Symbol	Definition
	ATTENTION: Identifies information that requires special consideration.
	TIP: Identifies advice or hints for the user, often in terms of performing a task.
	REFERENCE _ INTERNAL: Identifies an additional source of information within the bookset.
CAUTION	Indicates a situation which, if not avoided, may result in equipment or work (data) on the system being damaged or lost, or may result in the inability to properly operate the process.
	CAUTION: Indicates a potentially hazardous situation which, if not avoided, may result in minor or moderate injury. It may also be used to alert against unsafe practices.
	CAUTION: Symbol on the equipment refers the user to the product manual for additional information. The symbol appears next to required information in the manual.
	WARNING: Indicates a potentially hazardous situation which, if not avoided, can result in serious injury or death.
	WARNING symbol on the equipment refers the user to the product manual for additional information. The symbol appears next to required information in the manual.

IMPORTANT NOTICE

System Validation Test or Commissioning of the gas detection system is not complete until it is tested to verify that it is functioning according to its design objectives or specifications.

Validation includes, but is not limited to:

- Verification tests of the functions of each component in the individual system architecture.
- Verification that all inputs to the system result in the correct outputs.
- Verification that, where required, a back-up power supply system is in place.
- Verification that all personnel who will be working with and/or affected by the system have received proper instruction on use and purpose.

Table of Contents

Table of Contents

Symbol Definitions	i
IMPORTANT NOTICE	iii
Introduction	1
Restricted Materials Table for China RoHS.....	1
Warnings and Cautions	2
Installation	4
Locating the Sensor.....	4
Installation Height	5
Wall Mounting for Standalone/Network monitor	5
Mounting for Remote monitor	7
Duct Mounting.....	8
Special Duct Mount Installation.....	8
Wiring	10
Guidelines.....	10
Wiring Standalone monitor	10
Connecting a Remote monitor to the Standalone monitor....	12
Wiring Network Monitors	12
Installation Test	13
Standalone Model Operation	14
Start-Up Procedure	14
Network Model Operation	15
User Interface	16
Monitor Operation	17
Using the Programming Menus.....	17
Main Menu Options	17
Password Menu	18
Network Menu.....	18
Display Menu.....	19
Restore Menu.....	19
Temp Menu	20
Set Zero Menu.....	21
Set Span menu	22
TestMode Menu.....	23

Table of Contents

<u>Memory Menu</u>	<u>23</u>
<u>Quit Menu</u>	<u>23</u>
<u>Model Specific Menu Options</u>	<u>24</u>
<u>Standalone Model Relay Menu</u>	<u>24</u>
<u>Standalone Model Buzzer Menu</u>	<u>25</u>
<u>Standalone Model Alarm Menu</u>	<u>25</u>
<u>Network Relay Menu</u>	<u>27</u>
<u>Network Model Buzzer Menu</u>	<u>28</u>
<u>Network Model Alarm Menu</u>	<u>29</u>
<u>Remote Sensor</u>	<u>31</u>
<u>Description</u>	<u>31</u>
<u>Safety Information</u>	<u>31</u>
<u>Specifications</u>	<u>32</u>
<u>General Technical Specifications</u>	<u>32</u>
<u>Detection Ranges and Alarm Levels</u>	<u>33</u>
<u>Sensor Over Range</u>	<u>33</u>
<u>Periodic Inspection and Maintenance</u>	<u>35</u>
<u>Maintenance</u>	<u>35</u>
<u>Sensor Life Span</u>	<u>35</u>
<u>Troubleshooting</u>	<u>36</u>
<u>Annex A - BACnet and Modbus Objects on E³Point Network</u>	<u>39</u>
<u>BACnet Configuration</u>	<u>39</u>
<u>BACnet Objects Descriptions</u>	<u>39</u>
<u>Modbus Registers Description</u>	<u>40</u>
<u>BACnet Protocol Implementation Conformance Statement</u>	<u>40</u>
<u>Limited Warranty</u>	<u>45</u>
<u>Limited Warranty</u>	<u>45</u>
<u>Re-Stocking Policy</u>	<u>45</u>
<u>Exclusions</u>	<u>45</u>
<u>Warranty Limitation and Exclusion</u>	<u>46</u>
<u>Disclaimer of Unstated Warranties</u>	<u>46</u>
<u>Limitation of Liability</u>	<u>46</u>

Introduction

E³Point derives its name from: **E**nergy Management, **E**fficiency, and **E**conomic value in gas detection.

E³Point is an important part of toxic or combustible gas detection system that combines a gas sensor (electrochemical or catalytic type), a control unit, and a set of outputs (such as 4-20 mA current loop, buzzer and relays). The polycarbonate housing is resistant to rust, dents and corrosion.

There are 3 monitor models in the E³Point family: **Standalone**, **Remote** and **Network**. The **Standalone** monitor provides the full control unit, with a built in sensor and is capable of accepting one additional **Remote** sensor. This configuration allows the E³Point to detect two gases in two separate locations.

The E³Point **Network** platform supports different protocols over an RS-485 link, such as Modbus or BacNet MS/TP master. It is well suited for commercial use in parking garages and mechanical rooms. It is intended for connection to the 301-C or AA96D series controllers.

Installation is both economical and efficient because it is achieved in 3 easy steps (mounting, wiring and power-up). Units are shipped with a Quick Start Guide to support proper installation.

Restricted Materials Table for China RoHS

部件名称	有害物质					
	铅 (Pb)	汞 (Hg)	镉 (Cd)	六价铬 (Cr(VI))	多溴联苯 (PBB)	多溴二苯醚 (PBDE)
PCB 板	X	0	0	0	0	0

本表格中未列出的所有部件和配件包含的有害物质都没有超过 GB/T 26572 所要求的限制。

本表格依据 SJ/T 11364 的规定编制

○ : 表示该有害物质在该部件所有均质材料中的含量均在 GB/T26752 规定的限量要求以下。

× : 表示该有害物质至少在该部件的某一均质材料中的含量超出 GB/T26572 规定的限量要求。

2004Y2001C_1 A04826 China RoHS Declaration 01 (Pb PCB) 16 May

Warnings and Cautions

Warnings and Cautions

Warnings

- Power to the E3Point monitor must be off during installation and when installing the sensor cartridge.
- The installer must be grounded for ESD protection while handling the PC board (PCBA) and during installation of the monitor.
- Follow all local codes when installing the monitor.
- Operate, service, and use the monitor only as specified in the quick start guide and this technical manual. Failure to do so may impair the protection the monitor is designed to provide and may also void the warranty. The manual is available on the Honeywell Analytics website. You may scan the QR code below for easy access to product information:



- Calibration, set-up, and test modes are intended for use by trained personnel and service engineers only. Access to these modes is passcode protected.
- Follow local and site procedures when working with this monitor. If applicable, verify that the associated control panel is inhibited in order to prevent false alarms during installation. The procedures in the quick start guide and the product's technical manual must be followed carefully and performed only by trained personnel and service engineers.
- Use only accessories and parts meeting or exceeding Honeywell Analytics' specifications.
- Some monitors require warm-up time. See the appropriate sections in this technical manual for specific information.
- Ensure that the monitor screen is free of dirt and debris, and do not cover or paint over the monitor screen.
- Do not expose the monitor to electrical shock and/or continuous mechanical shock.

The warranty will be voided if the customer or any unauthorized service personnel attempt to repair the monitor

Cautions

- The E3Point monitor must be installed only by trained personnel and service engineers in accordance with local codes.
- The safety of any system incorporating the E3Point monitor is the responsibility of the assembler of the system.
- Protect the monitor from water, wash-down, and excessive humidity.
- To prevent electrical interference, keep the monitor and wire runs away from mercury vapor lights, variable speed drives, and radio repeaters.
- Protect the monitor from physical damage (fork lifts, etc.).
- Do not mount the monitor over a door in a refrigerated area.
- For critical locations, more than one monitor should be installed in each room.
- Never mount the sensor flat on a ceiling.
- Never mount the sensor on a vibrating surface.

Installation

Installation



WARNING: Some materials such as, but not limited to, tetraethyl lead, silicones, some sulfur, phosphorus, and chlorinated compounds, may have a poisoning effect resulting in a loss of sensitivity. Avoid installing the monitor in areas where these materials may be present.

Locating the Sensor

Considerations in locating the monitor

Installation Height:

- **Fastest Possible Leak Detection** – Mount the monitor near the potential leak sources
 - One monitor should be located in close proximity to each point where an emission is likely to occur
 - Indicated concentration may not be representative of personnel exposure
 - Easy access for the required calibration and maintenance could be compromised
- **Personnel Protection**
 - Mount the sensor at the installation heights shown in the table below
 - Gas is detected where it is accumulated – which may not be detected at the leak source.

Air Currents: If there are fans, wind, or other source of air movement, gases may tend to rise or collect in certain areas of a facility. The local air currents should be assessed to aid in selecting the sensor location. Air convection can often be more important in determining gas concentration areas than factors of Vapor Density.

Gas Emission Sources: As a rule, at least one sensor should be located in close proximity to each point where an emission is likely to occur.



CAUTION: Because each sensor can only “report” what it is detected at the place it is installed at a specific moment, it is very important that the sensor be located where leaks are most likely to occur.

Installation Height

Detected Gas		Relative Density (air = 1)	Installation Height
CO	Carbon monoxide	0.968	1–1.5 m (3–5 ft.) from floor
H ₂ S	Hydrogen sulfide	1.19	30 cm (1 ft.) from floor
*NO ₂	Nitrogen dioxide	1.58 (cold)	30 cm–1 m (1–3 ft.) from ceiling
O ₂	Oxygen	1.43	1–1.5 m (3–5 ft.) from floor
COMB	Most combustibles are heavier than air, with the exception of methane, hydrogen, ethylene and acetylene. Sensors for gases that are heavier than air should be installed approximately 30 cm (1 ft) from the floor. For combustibles that are lighter than air, sensors should be installed 30 cm (1 ft) from the ceiling, close to the potential leak source.		

* May differ in certain applications. Hot NO₂ from exhaust systems is lighter than ambient air.

Wall Mounting for Standalone/Network monitor

1. Verify that power to the monitor is off.
2. While properly grounded for ESD protection, remove the PCBA from the monitor. It is attached by a single center screw. Carefully place the PCBA in the enclosed antistatic envelope.
3. Drill two holes through the case and into the mounting surface; horizontally if mounting on a vertical surface or vertically if mounting to a standard electrical box as indicated below.

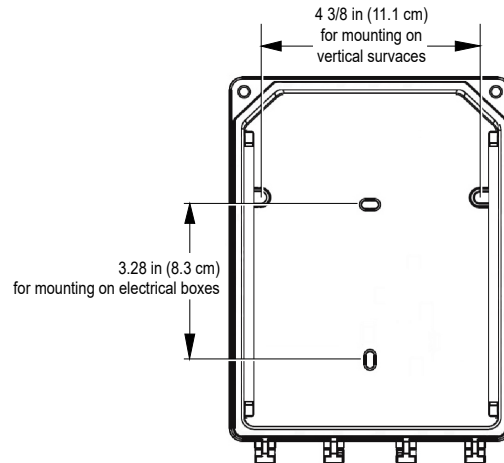

Installation

4. To mount the monitor, refer to the table for appropriate hardware and drill size. Use the enclosed mounting template to drill into the vertical surface if required.

Mounting Surface	Example Part	Description	Drill Bit Size
Drywall, Plaster, Wood Paneling	QTY (2) McMaster-Carr #97121A013	Rounded head Toggle Bolt · 6-32 · 3" long · 1-1/2" wingspan toggle · Pull Out Strength: 35 lbs	3/8"
Block, Brick, Concrete	QTY (2) McMaster-Carr #97026A021 AND QTY (2) McMaster-Carr #91555A111	Metal Anchor for Block and Brick · 1" long · Pull out Strength: 60 lbs AND Rounded Head Screw · No. 6, 7 or 8 sheet metal or wood screw · 2" long	1/4"
Electrical Box or Duct	As recommended by the manufacturer of the box or duct		N/A

5. Tighten the mounting bolts or screws to 8.7 in-lb (1 Nm) maximum.
6. Remove the metal grounding plate before removing the knockouts.
7. Remove one of the knockouts (depending on where cables will enter the housing) and affix appropriate conduit.
8. Run wiring through the conduit and the housing to the monitor, (See wiring section).
9. Reinstall the PCBA.
10. Install the sensor cartridge.
11. Complete wiring as shown in the [Wiring](#) section.
12. Close the cover and tighten the cover screws to 29.7 in-lb (3 Nm).
13. Restore power to the monitor.

Mounting for Remote monitor

The E3Point Remote Monitor is designed to be mounted in an extra wide (2 3/8") electrical box (not supplied) in the same way as a faceplate. Suggested electrical boxes include T&B BC1110, Hubbell 1110, OZ-Gedney 18112, Appleton 18112, Bowers 10612-BW, or Steel City 68371-12.

It does not fit on 4x4" steel boxes with a single gang mud ring, such as T&B 52CO or 52C13.

- Run the wires through the electrical box and connect to the remote monitor.
- Press the monitor (2) into the faceplate (1) and close and press the back cover (3) into the faceplate. You should hear a click.

Securely mount the monitor to the extra wide electrical box (4) using the appropriate screws (5)(not supplied).

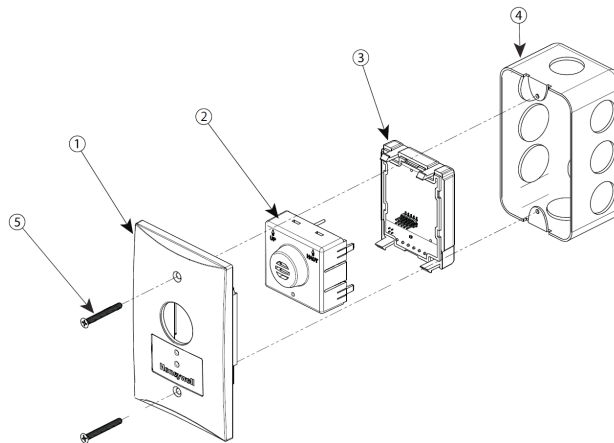

General Mounting Considerations:

- Must be easily accessible for calibration and maintenance.
- Mount the sensor close to the potential leak source for fastest possible leak detection.
- If personnel protection is the primary application, mount in the "breathing zone" (3.3–5 ft/1–1.5 m from the ground, within the range of a person's respiration area).
- Take air movement and ventilation patterns into account.
- See Warnings and Cautions on page 2 for additional considerations.



CAUTION: Use caution when opening the E3Point enclosure to avoid damage.

Installation

Duct Mounting

Special Duct Mount Installation

This option works best for airflows between 500–4000 ft./min.

The E³Point must be duct mounted using the custom box provided with the duct mount version. All of the components housed within the box are factory assembled.

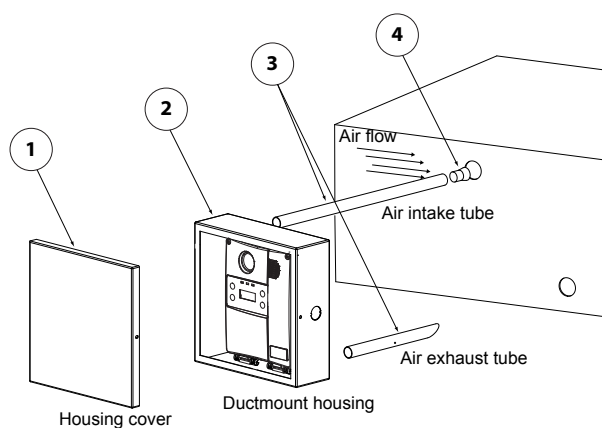

Figure 1. Duct Mounting

1. Verify that power to the monitor is off.
2. Measure and mark the holes for the intake and exhaust tubes.
3. Drill the holes in the duct for the sampling tubes (1 1/2 in., 38 mm) for the air intake tube, 1/2 in. (13 mm) for the air exhaust tube).
4. Affix intake and exhaust tubes to the duct mount housing.
5. Insert the tubes into the holes in the duct.



Ensure to orient the air holes on the air intake tube to face the airflow.

6. Orient the air holes on the air intake tube facing the airflow.
7. Attach the housing to the duct with four 8 x 3/4" galvanized or zinc-plated sheet metal screws (not provided).
8. While properly grounded for ESD protection, remove the PCBA from the monitor. It is attached by a single center screw. Carefully place the PCBA in the enclosed antistatic envelope.

Installation

9. Remove one of the knockouts (depending on where cables will enter the housing) and affix appropriate conduit.
10. Run wiring through the conduit and the housing to the monitor (See wiring section).
11. Re-install the PCBA.
12. Install the sensor cartridge.
13. Connect the wires (see the appropriate section below).
14. Screw the cover onto the monitor and replace the housing cover.
15. Restore power to the monitor.



CAUTION: Use caution when opening the E3Point duct enclosure and E3Point to avoid damage.

Wiring

Wiring

Guidelines

Follow local codes when sizing power wiring:

- Terminal Blocks, input, and communication: R/C (XCFR2) minimum 300 V, 10 A, 16-22 AWG solid or stranded
- Terminal blocks relays: R/C (XCFR2) minimum 300 V, 10 A, 14-22 AWG stranded, 16-22 AWG solid
- All communication wiring should be shielded.

Network cabling can extend up to 2000 feet (609 m) per channel. Daisy chain the network cable without T-taps. The 24V supply must be properly grounded in accordance to all local electrical codes. Power wiring must be grounded with a terminal ring at the screw and nut on the grounding plate inside the case.

Wiring Standalone monitor

Ground the shield at the main control panel. Connect the shield wire in the monitor terminal block labeled “shield.” Tape all exposed shield wire at the monitor to insulate it from the enclosure.

Circuit Board Connections

Connect the power wiring to terminal J1, communication wiring to terminal J2, and external devices (ventilators, strobes, etc. to relay terminals J5 or J6).

Main Circuit Board Connections

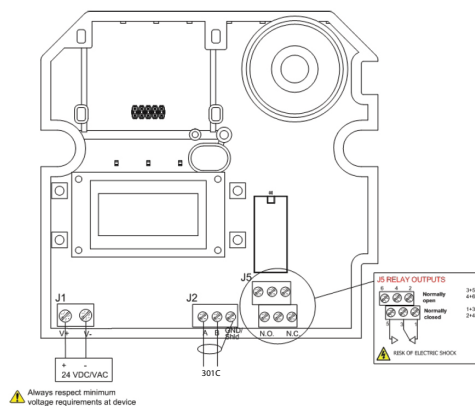

3-Wire Current Sink Output (DC supply only)

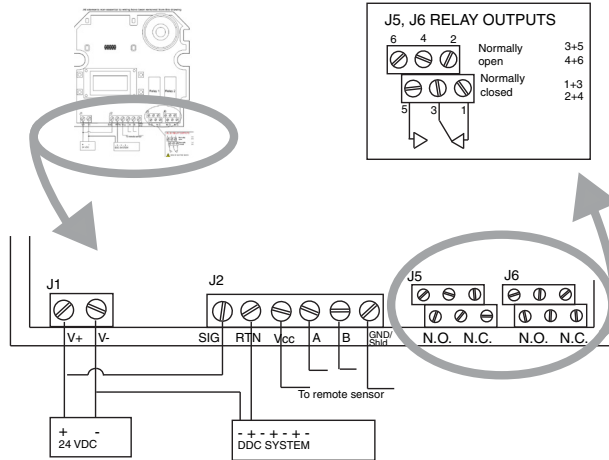

4-wire Current Sink Output

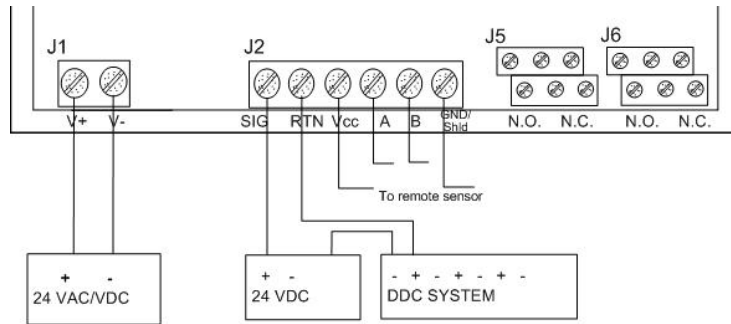

120 VAC Connection (model E3SAH only)

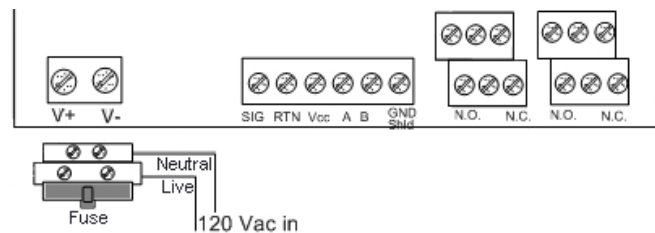

Wiring

The transformer is mounted under the PCBA. Connections to the power terminal are factory wired. Connect the live and neutral wires, as shown. Verify that power is off before connecting wires. Replace fuse with same type: 1A 250 VAC, T.

Connecting a Remote monitor to the Standalone monitor

The remote monitor can be connected only to an E3Point standalone monitor. For signal wiring, use shielded twisted pair cable. Remote monitors should have no more than 200 ft (61 m) wire.



The OUT1 and OUT2 connectors on the remote monitor's terminal are not used. Do not connect wires to these locations.

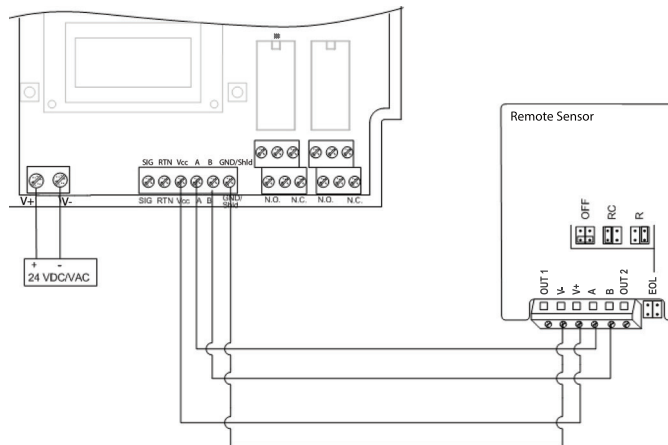

Wiring Network Monitors

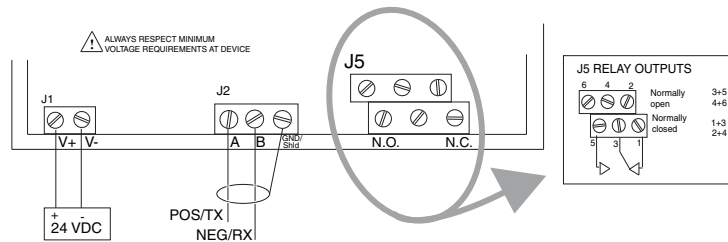

Installation Test

Once the monitor has been mounted and all wiring connections are complete, a test of the monitor's functions is recommended. It is necessary to access the monitor's programming menus to perform the test:

- Power up the monitor and allow 5 minutes for the warm-up procedure to complete (allow 15 minutes for the O₂ sensor).
- Press the **enter** on the front touchpad.
- The LCD displays the Password login screen. See [Password Menu](#).

Once in the programming menus, use the arrow key to scroll to the TestMode option. See [TestMode Menu](#).

The TestMode menu performs a test of all functions on the monitor. All outputs are activated according to their failsafe mode, relay setting, and buzzer setting. All functions are activated simultaneously for a maximum of 3 minutes (or until the user cancels the test) to ensure working order.



The monitor does not detect gas during this TestMode procedure.

Once all functions are confirmed in good working order, the monitor is completely functional.

Should any function fail the test, verify that all connections are correctly wired and re-test.

Standalone Model Operation

Standalone Model Operation

The E³Point gas monitors (Standalone and Network) are factory configured to conform to specific standards. It is designed to be operational after physical installation and warm-up procedures.

Start-Up Procedure

Before applying power, check all wiring for continuity, shorts, grounds, etc. After power-up, ensure the LEDs below are operational as follows:

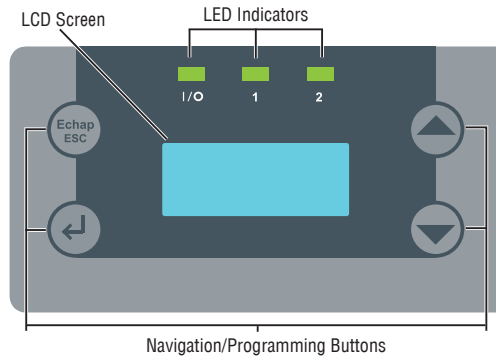

Figure 2. E³Point LCD

LED	Description	Display Modes
I/O	Power	Always on = Normal operation
		Always off = microcontroller fault or no power
		Blinking (twice per second) = self-test
1	Built-in sensor	Always on = Alarm A triggered
		Slow blink = Alarm B/C triggered (1 blink/second)
		Fast blink = Fault (4 blinks per second)
		Always off = normal operation
2	Remote Sensor	Always on = Alarm A triggered
		Slow blink = Alarm B triggered (1 blink/second)
		Fast blink = Fault (4 blinks per second)
		Always off = normal operation



There is no Alarm C option for the remote sensor (Z2).

Network Model Operation

The Network Model varies from the Standalone Model for Start-Up only in that the LEDs have different functions.

LED	Description	Display Modes
I/O	Power	Always on = Normal operation
		Always off = microcontroller fault or no power
		Blinking (twice per second) = self-test
1	Built-in sensor Alarm A	Always on = Alarm A triggered
		Slow blink = Alarm B/C triggered (1 blink/second)
		Fast blink = Fault (4 blinks per second)
		Always off = normal operation
2	Transmit	Blinks for communication and is always on when transmitting
		Always off = normal operation

Sensor Warm Up

When the monitor is first powered up, sensors must go through a 5 minute warm-up (15 minutes for the O₂ sensor), during which time the monitor displays **Warm-Up**. The 4-20 mA is maintained at 4 mA for all sensors; however, the O₂ sensor is maintained at (approximately) 17.4 mA (equal to 20.9%).

Allow the sensor to operate for 12 hours with the enclosure closed prior to testing the sensors. Optimal sensor performance is achieved 3 to 4 hours after initial power up.

Network Model Operation

User Interface

The E³Point gas monitors (Standalone and Network) are factory equipped with a 2 line, 8 character LCD screen that displays reading information and serves as an interface for programming functions and calibration.

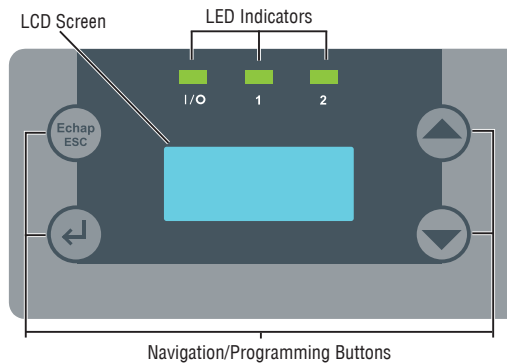





Figure 3. E³Point LCD

The LCD screen displays the readings in real time, including the type of gas detected, the concentration, and measurement value (% or ppm) and for which sensor (built-in and remote if present).

	Cancels a modification or exits a menu.
	Provides access to the programming menus and confirms a selection.
	Navigates through the menu options and increments/decrements values.
	

Monitor Operation

Using the Programming Menus

The programming menus provide a series of options that let you customize your gas detection system. Press the **enter** key to access the programming menus. If no buttons are pressed for 2 minutes, the monitor exits programming mode to normal operation.



CAUTION: Only qualified, knowledgeable personnel should use the programming functions of this monitor. Factory settings conform to specific standards. See [Specifications](#). Any changes made to Alarm Levels may affect manufacturer's stated standards compliance.

Main Menu Options

Each menu option provides access to further sub-menus. Consult the following pages of this manual for menu use instructions.



Menu options do not apply to Remote model

Menu Options	Description	Menu Type
Password	Protects programming menus from unauthorized access.	Shared menu
Network	Defines device address, baud rate, BACnet ID, or communication protocol (Network Model only).	Model specific menu *only for Network model
Display	Provides a choice of discrete display.	Shared menu
Relay	Defines whether the relays will be latched, failsafe or activated.	Model specific menu
Buzzer	Provides a choice between activated or silenced.	Model specific menu
Alarm	Allows configuration of various alarm levels .	Model specific menu
Temp	Sets the maximum temperature level.	Shared menu
Restore	Restores the device's factory configured calibration settings.	Shared menu
SetZero	Sets the sensor zero.	Shared menu
SetSpan	Calibrates the sensor span.	Shared menu

Monitor Operation

Menu Options	Description	Menu Type
TestMode	Simulates events for testing purposes without affecting the sensor readings. Used during installation.	Shared menu
Memory	Reserved for authorized Honeywell Analytics technicians only.	Shared menu
Quit?	Exits the programming menus and returns the device to normal operation mode.	Shared menu

Model Shared Menu Options

Password Menu

Access to the programming menus is password protected (password is **HA**). The Password screen displays after pressing the **enter** key.

Password
AA

- Press the arrow key (up or down) to change the first letter to **H**.
- Press **enter** and use the arrow keys to change the second letter to **A**.
- Press **enter** to confirm the password and access the menus.
- Use the arrow keys to scroll through the menu options.
- In the event of an entry error, the monitor returns to normal display mode. Restart the login process.

Network Menu

The Network menu contains several sub-menu options: Address, BaudRate, BACnet ID, and Protocol. Use the arrow keys to scroll to the desired option and press enter to select:

* Menu *
Network

Address: Use the arrow keys to increase or decrease the address value (from 001 to 254 in Modbus or 1 to 127 in BACnet) and press enter to confirm the desired address

BaudRate: Use the arrow keys to scroll through predefined baud rates (4800, 9600, 19200, 38400, 57600, 76800) and press enter to select.

Only 9600 baud is supported when the Modbus protocol is selected.

Display Menu

The Display menu selects the display language (English or Français) and whether the monitor display screen will be in Discrete mode or not. In Discrete mode, the screen powers off after three minutes of inactivity (activating the keypad will turn the screen back on).

* Menu *
Display

- Press **enter** from the main Display menu. The screen displays **Language**, or press an arrow key to display **Discrete**. Press **enter** to select.

Display
Language

- In the Language screen, use the arrow keys to scroll to **Français** or **English** and press **enter** to select.

Display
Discrete

- In the Discrete screen, use the arrow keys to scroll to **Yes?** or **No?** and press **enter** to select.

Restore Menu



CAUTION: Only qualified, knowledgeable personnel should use the Restore function of this monitor. Factory calibration settings conform to specific standards. Any changes made may affect manufacturer's stated standards compliance.

The Restore menu allows users to restore all calibration information to factory configured settings. Press **enter** to access the Restore menu.

* Menu *
Restore

- Use the arrow keys to scroll to **Yes** (or **No**) and press **enter** to select.

Restore
Yes

Monitor Operation

The screen briefly displays a success message and returns to the main menu option.

Restore
Success

Temp Menu

The Temp menu allows users to define the maximum temperature for the device temperature alarm, which can be used to activate the device connected to the relay.

* Menu *
Temp

Press **enter** to access the Temp menu, then select either **Disable** or **Enable**.

Temp
Enable

Use the arrow keys to select the temperature scale (either **oC** or **oF**) and press **enter** to select (the underlined value). This affects local display only and is not stored in memory—it is a conversion aid.

Limit
oC

- Use the arrow keys to increase or decrease the value to the desired level and press **enter**.

Limit
50oC

An alarm (or relay) as chosen at programming time will be triggered when the temperature reaches the specified level. **TEMP LIMIT** will display on the LCD.



The temperature measured represents the monitor's internal reading and may differ from external temperatures by up to 10°C.

The monitor does not display temperature readings.

Set Zero Menu



Only use the Set Zero function when the monitor no longer displays zero. See [Periodic Inspection and Maintenance](#).

This option allows users to set the sensor Zero. In the main Set Zero screen, press **enter** to begin. If there is a remote sensor connected, on the Standalone Mode, you must scroll to select **Z1** (built-in sensor) or **Z2** (remote sensor).

* Menu *
Set Zero

Set Zero
Z1

- Before starting the calibration, connect the regulator to the appropriate cylinder (nitrogen for all sensors except combustible, which uses air).
- Adjust the flow rate to the indicated rate.
- Connect the tubing from the regulator to the sensor calibration cap as shown in [Figure 4](#).
- Let the gas flow for at least 2 minutes before starting calibration.
- The next screen requests confirmation. Use the arrow keys to display **Yes** and press **enter** to confirm.

Set Zero
Yes

A confirmation screen briefly displays and the zero calibration begins.

A success or failure message displays and the screen returns to the main menu option.

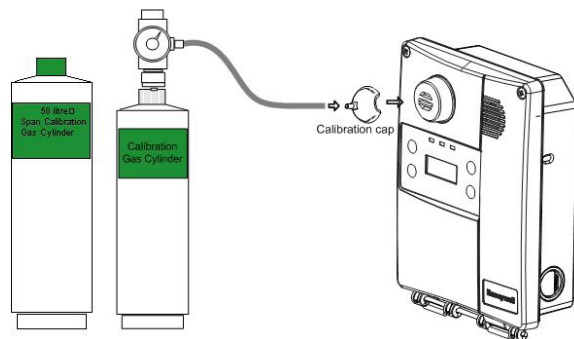

Figure 4. Calibration Installation

Monitor Operation

Set Span menu



WARNING: If the calibration gas concentration exceeds alarm setpoints, alarms will be triggered. Either change alarm levels so the alarms are not triggered, or put the entire system in service mode so no external equipment (lights, fans, ventilators, buzzers) will be activated.



Only use the Set Span function when inspection or calibration maintenance indicate that it is necessary. See [Periodic Inspection and Maintenance](#).

This option allows users to calibrate the sensor's span. In the main Set Span screen, press **enter** to begin. If there is a remote sensor connected, you must scroll to select **Z1** (built-in sensor) or **Z2** (remote sensor).



Before starting calibration, connect the regulator to the gas cylinder.

- Adjust the flow rate to 0.5 L/min.
 - Connect the tubing from the regulator to the sensor calibration cap. See [Figure 4](#).
 - Let the gas flow for at least 2 minutes before starting the calibration.
-



If the gas is not allowed to flow for at least 3 minutes, it will affect the calibration accuracy.

The next screen allows you to specify the span calibration gas concentration value.

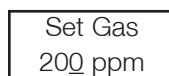

- Use the arrow keys to increase or decrease the value and press **enter** to select.
- The next screen requests confirmation.



- Press **enter** to confirm and the screen displays the concentration during calibration.

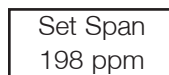

Monitor Operation

A success or failure message displays and the screen returns to the main menu option.

TestMode Menu

The TestMode menu performs a test of all functions on the monitor. All outputs are activated according to their failsafe mode, relay setting, and buzzer setting. All functions are activated simultaneously for a maximum of 3 minutes (or until the user cancels the test) and the 4-20mA output is saturated at 20 mA to ensure working order. The monitor does not detect gas during this TestMode procedure. Press **enter** to access the TestMode.

```
* Menu *
TestMode
```

- Use the arrow keys to scroll to **Yes** (or **No**) and press any key to begin the test sequence.

```
TestMode
  Yes
```

- To cancel the test, press **enter** at anytime when **Stop** displays.

```
TestMode
  Stop
```

Memory Menu



This menu is reserved for Honeywell Analytics authorized technicians' use only. It contains no modifiable values or information for the user. Changing values may damage the monitor.

Quit Menu

The Quit menu exits the programming functions and returns the screen to its normal display. Press **enter** to exit the programming function.

```
* Menu *
Quit?
```

Monitor Operation

Model Specific Menu Options

Standalone Model Relay Menu

The Relay menu allows users to select **Latch**, **Failsafe**, or **SetDelay**. Press **enter** to access the Relay menu options, then scroll to select Relay #1 or Relay #2.



- Use the arrow keys to scroll to the desired option and press **enter** to select one of the four following options:



Latch: Keeps relays on even after an event has returned to normal. Use the arrow keys to select **Yes** or **No** and press **enter** to confirm the setting. Once a latched relay is activated, press and hold a keypad button for 5 seconds to return relays to their normal position.

Failsafe: Relays will be on in normal conditions but will de-energize during a controller fault or shutdown, or when an alarm is triggered. In the Failsafe menu, use the arrow keys to select either **Yes** or **No** and press **enter** to confirm.

Activate: Relay #2 only. Can be set to activate with B (Alarm B) or F (Fault).

SetDelay: Allows users to specify a **Before** and **After** delay period for relay alarm activation and deactivation.



- In the SetDelay menu, use the arrow keys to display either **Before** or **After** and press **enter** to select.



- For the Before (or After) screen, use the arrow keys to increase the delay in seconds. When the desired value is reached, press **enter** to confirm.



Monitor Operation

- Press **enter** again to confirm the SetDelay, or use the arrow keys to select **No** and cancel the procedure.

Standalone Model Buzzer Menu

The Buzzer menu allows users to select whether or not the built-in audible alarm can be silenced by pressing a keypad button and which events will activate the buzzer.

* Menu *
Buzzer

- Press **enter** in the main Buzzer menu screen. The Buzzer screen displays either **Activate** or **Silence**.
- Use the arrow keys to scroll to the desired option and press **enter** to select.

Buzzer
Activate

If **Silence** is selected, the buzzer can be deactivated (without affecting the event) by pressing and holding any key on the monitor for 5 seconds.

Select **Activate** to display available menu options:

- B: The buzzer will activate when alarm level B is reached.
F: The buzzer will activate upon a system or sensor fault.
Disable: Buzzer is completely deactivated. However, if there is a fault alarm, the buzzer will sound one brief beep once every 10 minutes.

Standalone Model Alarm Menu



CAUTION: Only qualified, knowledgeable personnel should use the programming functions of this monitor. Factory settings conform to specific standards (see [Specifications](#)). Any changes made to Alarm Levels may affect manufacturer's stated standards compliance.

The Alarm menu allows users to define different alarm levels than the factory settings. Press **enter** to access the Alarm menu options. If there is a remote sensor connected, scroll to select either **Z1** (built-in sensor) or **Z2** (remote sensor).

* Menu *
Alarm

Alarm
Z1

- Use the arrow keys to scroll to the **Alarm A, B, or C** option and

Monitor Operation

press **enter** to select. The screen displays the default alarm level.

Alarm
A



There is no Alarm C option for the remote sensor (Z2).

- Use the arrow keys to increase or decrease the value to the desired level and press **enter**.

Alarm A
0025 PPM



When alarm settings are modified by the customer, the new values are stored in the main device and do not need to be modified again when a sensor is replaced.



WARNING: If a gas sensor for a different type of gas is installed, the previously stored values will no longer be valid and must be corrected.

- The next screen displays the hysteresis value. Use the arrow keys to increment or decrement the value and press **enter**.

Hyst A
-05

- The Hyst(eresis) screen displays. This value, added to the alarm level, tells the monitor at which level to deactivate the alarm (e.g. Alarm level A is 25 ppm, minus a hysteresis level of -05, gives a deactivation level of 20 ppm). Use the arrow keys to increase or decrease the value and press **enter**. A confirmation screen displays. Press **enter** to confirm.

SetAlarm
Yes

The screen briefly displays a success message and returns to the main menu option.

Network Relay Menu

The Relay menu allows users to select if the relays will be **Latch**, or **Activated**. Press **enter** to access the Relay menu options.

* Menu *
Relay

- Use the arrow keys to scroll to the desired option and press **enter** to select one of the following four options:

Relay
Latch

Latch: Keeps relays on even after an event has returned to normal. Use the arrow keys to select **Yes** or **No** and press **enter** to confirm the setting. Once a latched relay is activated, press and hold a keypad button for 5 seconds to return relays to their normal position (if trigger condition has resolved).

Failsafe: Failsafe mode is not supported on Network models.

Activate: If the monitor is configured with the Modbus or BACnet communication protocol, these options are replaced with Network. This menu option is inactive (no action can be taken from this option) as this function is managed by the network controller.

SetDelay: Allows users to specify a **Before** and **After** delay period for relay alarm activation and deactivation.

SetDelay
Before

- In the SetDelay menu, use the arrow keys to display either **Before** or **After** and press **enter** to select.

Before
000 sec

- In the **Before** (or **After**) screen, use the arrow keys to increase the delay in seconds (10 second increments, maximum of 360). When the desired value is reached, press **enter** to confirm.

SetDelay
Yes

- Press **enter** again to confirm the SetDelay (or use the arrow keys to select **No** and cancel the procedure).

Monitor Operation



Programming Delay, Failsafe, and Latch functions directly on the E³Point Network transmitter is NOT recommended, because local settings will override network settings. These functions should typically be programmed directly from the Network Control device.

Network Model Buzzer Menu

The Buzzer menu allows users to select whether or not the built-in audible alarm can be silenced by pressing a keypad button and which events will activate the buzzer.

* Menu *
Buzzer

- Press **enter** in the main Buzzer menu screen. The Buzzer screen displays either **Activate** or **Silence**.
- Use the arrow keys to scroll to the desired option and press **enter** to select.

Buzzer
Activate

If **Silence** is selected, the buzzer can be deactivated (without affecting the event) by pressing and holding any key on the monitor for 5 seconds.

Select **Activate** to display available menu options:

- Network: If the monitor is configured with the Modbus or BACnet communication protocol, these options are replaced with Network. No action can be taken from this option: it simply informs you that the buzzer is controlled by the network master device.
- Disable: Only available if the monitor is configured to emulate a 201T (previous generation of Honeywell Analytics gas monitors for toxic and combustible gases).



When the E³Point Network Model is configured in 201T EMU mode, the controller device controls the relay and buzzer together; they cannot be controlled separately.

Network Model Alarm Menu



CAUTION: Only qualified, knowledgeable personnel should use the programming functions of this monitor. Factory settings conform to specific standards (see [Specifications](#)). Any changes made to Alarm Levels may affect manufacturer's stated standards compliance.

The Alarm menu allows users to define different alarm levels than the factory settings. Press **enter** to access the Alarm menu options. If there is a remote sensor connected, scroll to select **Z1** (built-in sensor) or **Z2** (remote sensor, not available on Network Model).

* Menu *
Alarm

Alarm
Z1

- Use the arrow keys to scroll to the **Alarm A, B, or C** option and press **enter** to select. The screen displays the default alarm level.

Alarm
A

- Use the arrow keys to increase or decrease the value to the desired level and press **enter**.

Alarm A
0025 PPM



When alarm settings are modified by the customer, the new values are stored in the main device and do not need to be modified again when a sensor is replaced.



WARNING: If a different type of gas sensor cartridge is installed, the previously stored values will no longer be valid and must be corrected.

- The next screen displays the hysteresis value. Use the arrow keys to increment or decrement the value and press **enter**.

Hyst A
-05

Monitor Operation

- The Hyst(eresis) screen displays. This value, added to the alarm level, tells the monitor at which level to deactivate the alarm (e.g. Alarm level A is 25 ppm, minus a hysteresis level of -05, gives a deactivation level of 20 ppm). Use the arrow keys to increase or decrease the value and press **enter**. A confirmation screen displays. Press **enter** to confirm.

SetAlarm Yes

The screen briefly displays a success message and returns to the main menu option.

Remote Sensor

Description

The E³Point Remote Sensor provides continuous monitoring for one of the following gases in ambient air: CO, H₂S, O₂, NO₂, and combustible gases. Connected to an E³Point Standalone monitor can be used with an E³Point Remote to provide dual protection (a second location or to detect a different gas type).

Safety Information

Users of the E³Point Remote Sensor should fully understand the installation, operating and maintenance instructions, otherwise protection provided by the monitor may be impaired. Read the following warnings before using the monitor.

WARNING:



- **Install according to local electrical regulations and codes.**
- **Installation should be performed by qualified personnel.**
- **Do not paint over the sensor screen.**
- **Ensure the sensor screen is free of dirt and debris.**
- **Ensure the sensor screen is not covered.**
- **Do not expose the monitor to electrical shock or continuous mechanical shock.**
- **Do not expose the sensor to high pressure water spray.**
- **Do not use the monitor if it is damaged. Inspect the monitor before use. Look for cracks, missing metals, or plastics. If the monitor is damaged, contact Honeywell Analytics immediately.**
- **The warranty will be voided if the customer or any unauthorized service personnel attempts to repair the monitor.**



To change a sensor cartridge, disconnect all power to the device, remove the back cover, and pull out the “smart sensor” cartridge and press the replacement cartridge into place. Once the Smart Sensor is firmly in place, replace the back cover and reconnect power. *Use caution when pressing the Smart Sensor into place to avoid bending the pins.*

See [Alarm Menu](#) for special instructions for changing sensor gas types.

Specifications

General Technical Specifications

Uses	Standalone duct or wall mounted gas monitor with optional additional Remote monitor.	
	Network duct or wall mounted gas monitor. Communicates with 301C (or AA96D) at 9600 Baud.	
Size	Standalone/Network monitor (H x W x D): 20.56 x 14.90 x 6.72 cm (8.09 x 5.87 x 2.65")	
	Remote monitor (H x W x D): 3.5 x 4.5 x 6.5 cm (1.36 x 1.75 x 2.56") 38 g (1.34 oz)	
Electrical Ratings	Standalone/Network monitor 24 Vac, 350mA, 60 Hz 24 Vdc, 350 mA	Remote monitor: Class 2 or limited power source (lps) only. Electro-Chem Sensor: 10 - 24 Vdc, 50 mA Catalytic Bead Sensor: 10 - 16 Vdc, 100 mA
	E3SAH only: 120 Vac, 75 mA	
Sensor Types and Operating Parameters	Electro-Chemical – (CO, NO ₂ , H ₂ S, O ₂); Catalytic Bead – (CH ₄ , H ₂ C ₃ H ₈)	
	Indoor use, Maximum altitude: 2000 M, 15 – 80% RH Response time: T90 < 50 seconds; Response time with ECLAB (water shield): T90 < 240 seconds All sensors except CO: -40 to 50°C (-40 to 122°F) CO: -20 to 50°C (-4 to 122°F) CO for UL 2075: 15 - 35°C (59 - 95°F)	
Outputs	Standalone monitor 2 DPDT relays, 5 A @ 250 Vac and 30 Vdc, 4-20 mA	Network monitor 1 DPDT relay, 5 A @ 250 Vac and 30 Vdc MODbus and BACnet MS/TP master
	Remote monitor – Provides MODbus signal back to Standalone monitor for processing. 4-20 mA output not available for Remote monitor. OUT1 and OUT2 are not used.	
Display	Standalone/Network monitor – 8 character, 2 line backlit LCD	
Visual Indicators	Standalone monitor Green LED: Power Amber LED 1: Alarm/Fault Amber LED 2: Alarm/Fault	Network monitor Green LED: Power Amber LED 1: Alarm/Fault Amber LED 2: Transmission
	Remote monitor – Amber LED: Transmission	
Audible Alarm	Standalone/Network monitor - > 85 dBA at 3 m (10 ft)	

General Technical Specifications

Enclosure	Polycarbonate
Certification	Safety Requirements For Electrical Equipment For Measurement, Control, And Laboratory Use - Part 1: General Requirements [UL 61010-1:2012 Ed.3+R:29Apr2016] Safety Requirements For Electrical Equipment For Measurement, Control, And Laboratory Use – Part 1: General Requirements (R2017) [CSA C22.2#61010-1-12:2012 Ed.3+U1;U2]

Detection Ranges and Alarm Levels

Gas Detected	Resolution	Range	Alarm A	Alarm B	Alarm C	Maximum Overload	
CO *	Carbon monoxide	1 ppm	0-250 ppm	25 ±2 ppm	100 ±5 ppm	200 ±10 ppm	500 ppm
H ₂ S	Hydrogen sulfide	0.1 ppm	0-50 ppm	10 ppm	15 ppm	20 ppm	150 ppm
NO ₂	Nitrogen dioxide	0.1 ppm	0-10 ppm	0.7 ppm	2 ppm	9 ppm	150 ppm
O ₂	Oxygen	0.1%vol	0-25%vol	19.5%vol.	22%vol.	22.5%vol	100%vol
H ₂	Hydrogen	0.5% LEL	0-100%LEL	25%LEL	50%LEL	90%LEL	100% LEL
CH ₄	Methane	0.5% LEL	0-100%LEL	25%LEL	50%LEL	90%LEL	100% LEL
C ₃ H ₈	Propane	0.5% LEL	0-100%LEL	25%LEL	50%LEL	90%LEL	100% LEL
*Sensor exposure to gas concentration that may result in permanent damage to the sensor							
* Tested by Intertek to UL 2075 for Sensitivity, Selectivity, and Electrical Supervision at 23 ±3 °C (73 ±5°F) and 50 ±20 %RH							

Sensor Over Range

- Sensor over range occurs whenever the detected gas concentration level is higher than the full scale value of the sensor.
- When an over range condition occurs, the LCD displays “OVR RANGE” and the buzzer sounds for 50 milliseconds, once every 10 minutes.
- The LED blinks once per second normally but twice per second during an over range condition.
- When the gas concentration falls back within the full scale range of the cell, the the buzzer is silenced and the LCD displays the current concentration.

Specifications

- After an over range occurrence, the LCD will display an asterisk appended after the concentration level in this form:

xxxPPM*

where “xxx” is the current gas level. For combustible and oxygen sensors, this will appear as “xx.x%*”, where “xx.x” is the percent of full scale.

- To clear the appended asterisk from the display, press the ESC key for 8 seconds.
- On network monitors (301-C systems, for example), the over range warning states are available through warning flag #Z when connected to a BACnet building automation system. Over range warning states are available through the reliability property of the sensor analog input object (AIO).
- After an over range occurrence, the LCD will display an asterisk appended to the concentration level in this form:

xxxPPM*

where “xxx” is the current gas level. For combustible and oxygen sensors, this will appear as “xx.x%*”, where “xx.x” is the percent of full scale.

- To clear the asterisk from the display, press the ESC key for 8 seconds.

NOTE: If the system has experienced an over range condition, the sensor should be bump tested to verify that it still responds to the presence of gas. It should also be recalibrated at the next maintenance interval. See [Periodic Inspection and Maintenance](#).



To change a sensor cartridge, cut all power to the device and simply pull out the “smart sensor” cartridge and press the replacement cartridge into place. Be sure TOP/HAUT is toward the top of the monitor. Once the Smart Sensor is firmly in place, reconnect power. *Use caution when pressing the Smart Sensor cartridge into place to avoid bending the pins.*

See [Alarm Menu](#) in the Using the Programming Menus, section for special instructions for changing sensor gas types.

Periodic Inspection and Maintenance

This monitor requires regular inspection, including gas tests. The frequency will be determined by the operating conditions, which includes extreme temperatures, exposure to contaminants or gas. Inspect the monitor at least every 6 months.

Contact a Honeywell Sales or Service representative for information about maintenance. Calibration kits with instructions are available from Honeywell.

Maintenance

The monitor will provide years of service with minimal care.

- Inspect the monitor at least every 6 months.
- Visually inspect at regular intervals to ensure optimum operating condition (no breakage, sensor filter not blocked or clogged, etc.).
- An accurate maintenance log of all maintenance, calibration, gas tests, and occurrences must be maintained for the proper service of this product.
- Do not expose the sensor to high pressure water spray. Sensors should not be exposed to solvents.
- Clean the exterior with a soft, damp cloth. Do not use solvents, soaps, or polishes.
- Do not immerse the monitor in liquids.

Sensor Life Span

Sensor life span may be affected by certain operating conditions or by exposure to concentrations higher than the detection range.

Sensor Type	Life Span Specifications (typical)
CO	6 years, normal use at temperatures > -10°C
H ₂ S	2 years, in air
NO ₂	2 years, in air
O ₂	2 years until readings are at 85% of original 20.9% input
COMB	2 years, in air

Troubleshooting

Troubleshooting

If the E³Point Standalone or Network encounters errors, the LCD will display a 2-digit error code. The following table provides an explanation of these codes. **Contact Technical Services if any of these error codes appear.**

Error Code	Description
01	Main board eeprom error
02	Main board power glitch
03	Sensor board eeprom error
04	Sensor board eeprom uninitialized
05	Sensor board ADC failure
06	Sensor board ADC high saturation/clipping
07	Sensor board ADC low saturation/clipping
08	Sensor span gain not calibrated
09	Sensor not responding to span calibration
10	Sensor unstable while in span calibration
11	Sensor span gain too high
12	Sensor span gain too low
13	Sensor baseline not calibrated
14	Sensor baseline offset too high
15	Sensor baseline offset too low
16	Sensor reflex test (self-test) failed. See Sensor Over Range in Specifications.
17	Sensor end of life reached
18	Sensor due for calibration
19	Temperature sensor ADC signal too high
20	Temperature sensor ADC signal too low
21	Power overload caused by the presence of two high-powered sensors
22	Remote sensor communication error

If an O₂ sensor displays 0% and is in Alarm A status when no nitrogen is present, the sensor may be missing or defective. Contact Technical Services.

Annex A - BACnet and Modbus Objects on E³Point Network

The E³Point Network can be factory configured with optional communication types: BACnet or Modbus. Each of these communication protocols has its own specific objects.

Honeywell recommends that appropriate measures be taken to ensure security since BACnet and Modbus are not inherently secure. The installer takes all responsibility for protecting the controller from malicious network traffic.

BACnet Configuration



The E3Point is an MSTP Master Device and supports Dynamic Device Binding (WHOIS/IAM), which is part of BACnet protocols DM-DDB-B and DM-DOB-B (see the [Protocol Implementation Conformance Statement](#) section for details).

BACnet Objects Descriptions

Each measurement type has Analog Input (AI), Analog Value (AV), Binary Output (BO) and Binary Value (BV) objects. The table below defines each object and lists the default setting:

Type	Name	Description	Read/Write
AI	Conc.	The gas reading	R
AV	Alr A	The level at which Alarm A will be triggered	R/W
AV	Hyst A	Alarm A hysteresis offset (Alr A + Hyst A = level at which alarm is deactivated)	R/W
AV	Alr B	The level at which Alarm B is triggered	R/W
AV	Hyst B	Alarm B hysteresis offset (Alr B + Hyst B = level at which alarm is deactivated)	R/W
BV	Hi Temp Fault	Temperature High Level limit	R
BO	Relay	Actual buzzer status (on or off)	R/W
BO	Buzzer	Actual relay status (on or off)	R/W

Annex A - BACnet and Modbus Objects on E3Point Network

Modbus Registers Description

MODBUS (RTU)	
Number	Description
21	Reading value
23	Divisor of reading value to obtain concentration
26	Sensor status
27	High temp warning status
34	The level at which Alarm A is triggered
35	Alarm A hysteresis offset (Alr A + Hyst A = level at which alarm is deactivated)
36	The level at which Alarm B is triggered
37	Alarm B hysteresis offset (Alr B + Hyst B = level at which alarm is deactivated)
38	The level at which Alarm C is triggered
39	Alarm C hysteresis offset (Alr C + Hyst C = level at which alarm is deactivated)
61	Temperature High Level limit
66	Actual buzzer status (on or off)
70	Actual relay status (on or off)



The E³Point must not be written to as this could compromise the gas detection function.

BACnet Protocol Implementation Conformance Statement

BACnet Protocol Implementation Conformance Statement

Date: 2008-11-05

Vendor Name: Honeywell

Product Name: E3Point

Product Model Number:

Applications Software Version: 1.0

Firmware Revision:

BACnet Protocol Revision: 1.0

Product Description:

BACnet Standardized Device Profile (Annex L) :

- BACnet Operator Workstation (B-OWS)
- BACnet Building Controller (B-BC)
- BACnet Advanced Application Controller (B-AAC)
- BACnet Application Specific Controller (B-ASC)
- BACnet Smart Sensor (B-SS)
- BACnet Smart Actuator (B-SA)

List all BACnet Interoperability Building Blocks Supported (Annex K):

Data Sharing

- Data Sharing-ReadProperty-A (DS-RP-A)
- Data Sharing-ReadProperty-B (DS-RP-B)
- Data Sharing-ReadPropertyMultiple-A (DS-RPM-A)
- Data Sharing-ReadPropertyMultiple-B (DS-RPM-B)
- Data Sharing-ReadPropertyConditional-A (DS-RPC-A)
- Data Sharing-ReadPropertyConditional-B (DS-RPC-B)
- Data Sharing-WriteProperty-A (DS-WP-A)
- Data Sharing-WriteProperty-B (DS-WP-B)
- Data Sharing-WritePropertyMultiple-A (DS-WPM-A)
- Data Sharing-WritePropertyMultiple-B (DS-WPM-B)
- Data Sharing-COV-A (DS-COV-A)
- Data Sharing-COV-B (DS-COV-B)

BACnet Protocol Implementation Conformance Statement

- Data Sharing-COVP-A (DS-COVP-A)
- Data Sharing-COVP-B (DS-COVP-B)
- Data Sharing-COV-Unsolicited-A (DS-COVU-A)
- Data Sharing-COV-Unsolicited-B (DS-COVU-B)

Scheduling

- Scheduling-A (SCHED-A)
- Scheduling-Internal-B (SCHED-I-B)
- Scheduling-External-A (SCHED-E-B)

Trending

- Viewing and Modifying Trends-A (T-VMT-A)
- Trending-Viewing and Modifying Trends-Internal-B (T-VMT-I-B)
- Trending-Viewing and Modifying Trends-External-B (T-VMT-E-B)
- Trending-Automated Trend Retrieval-A (T-ATR-A)
- Trending-Automated Trend Retrieval-B (T-ATR-B)

Network Management

- Network Management-Connection Establishment-A (NM-CE-A)
- Network Management-Connection Establishment-B (NM-CE-B)
- Network Management-Router Configuration-A (NM-RC-A)
- Network Management-Router Configuration-B (NM-RC-B)

Alarm and Event Management

- Alarm and Event-Notification-A (AE-N-A)
- Alarm and Event-Notification Internal-B (AE-N-I-B)
- Alarm and Event-Notification External-A (AE-N-E-B)
- Alarm and Event-ACK-A (AE-ACK-A)
- Alarm and Event-ACK-B (AE-ACK-B)
- Alarm and Event-Alarm Summary-A (AE-ASUM-A)
- Alarm and Event-Alarm Summary-B (AE-ASUM-B)
- Alarm and Event-Enrollment Summary-A (AE-ESUM-A)
- Alarm and Event-Enrollment Summary-B (AE-ESUM-B)

BACnet Protocol Implementation Conformance Statement

- Alarm and Event-Information-A (AE-INFO-A)
- Alarm and Event-Information-B (AE-INFO-B)
- Alarm and Event-LifeSafety-A (AE-LS-A)
- Alarm and Event-LifeSafety-B (AE-LS-B)

Device Management

- Device Management-Dynamic Device Binding-A (DM-DDB-A)
- Device Management-Dynamic Device Binding-B (DM-DDB-B)
- Device Management-Dynamic Object Binding-A (DM-DOB-A)
- Device Management-Dynamic Object Binding-B (DM-DOB-B)
- Device Management-DeviceCommunicationControl-A (DM-DCC-A)
- Device Management-DeviceCommunicationControl-B (DM-DCC-B)
- Device Management-Private Transfer-A (DM-PT-A)
- Device Management-Private Transfer-B (DM-PT-B)
- Device Management-Text Message-A (DM-TM-A)
- Device Management-Text Message-B (DM-TM-B)
- Device Management-TimeSynchronization-A (DM-TS-A)
- Device Management-TimeSynchronization-B (DM-TS-B)
- Device Management-UTCTimeSynchronization-A (DM-UTC-A)
- Device Management-UTCTimeSynchronization-B (DM-UTC-B)
- Device Management-ReinitializeDevice-A (DM-RD-A)
- Device Management-ReinitializeDevice-B (DM-RD-B)
- Device Management-Backup and Restore-A (DM-BR-A)
- Device Management-Backup and Restore-B (DM-BR-B)
- Device Management-List Manipulation-A (DM-LM-A)
- Device Management-List Manipulation-B (DM-LM-B)
- Device Management-Object Creation and Deletion-A (DM-OCD-A)
- Device Management-Object Creation and Deletion-B (DM-OCD-B)
- Device Management-Virtual Terminal-A (DM-VT-A)
- Device Management-Virtual Terminal-B (DM-VT-B)

BACnet Protocol Implementation Conformance Statement

Segmentation Capability :

<input type="checkbox"/> Segmented requests supported	<input type="checkbox"/> Window Size_____
<input type="checkbox"/> Segmented responses supported	<input type="checkbox"/> Window Size : Take maximum Windows size supported by the other device

Standard Object Types Supported

Analog Input Analog Value Binary Value Binary Output Device	For all objects: 1) Cannot be dynamically createable using CreateObject service 2) Cannot be dynamically deletable using DeleteObject service 3) No optional properties supported 4) No additional writable properties exist 5) No proprietary properties exist 6) No range restriction
---	---

Data Link Layer Options:

- BACnet IP, (Annex J)
- BACnet IP, (Annex J), Foreign Device
- ISO 8802-3, Ethernet (Clause 7)
- ANSI/ATA 878.1, 2.5 Mb. ARCNET (Clause 8)
- ANSI/ATA 878.1, RS-485 ARCNET (Clause 8), baud rate(s)
- MS/TP master (Clause 9), baud rate(s): 4800, 9600, 19200, 38400, 57600, 76800
- MS/TP slave (Clause 9), baud rate(s): 9600
- Point-To-Point, EIA 232 (Clause 10), baud rate(s):
- Point-To-Point, modem, (Clause 10), baud rate(s):
- LonTalk, (Clause 11), medium:
- Other:

BACnet Protocol Implementation Conformance Statement

Device Address Binding:

Is static device binding supported? (this is currently necessary for two-way communication with MS/TP slaves and certain other devices).

- Yes No

Networking Options:

- Router, Clause 6 - List all routing configurations, e.g., ARCNET-Ethernet, Ethernet-MS/TP, etc.
- Annex H, BACnet Tunneling Router over IP
- BACnet/IP Broadcast Management Device (BBMD)

Does the BBMD support registrations by Foreign Devices?

- Yes No

Character Sets Supported:

Indicating support for multiple character sets does not imply that they can all be supported simultaneously.

- | | | |
|---|---|-------------------------------------|
| <input checked="" type="checkbox"/> ANSI X3.4 | <input type="checkbox"/> IBM/Microsoft DBCS | <input type="checkbox"/> ISO 8859-1 |
| <input type="checkbox"/> ISO 10646 (UCS-2) | <input type="checkbox"/> ISO 10646 (UCS-4) | <input type="checkbox"/> JIS C 6226 |

If this product is a communication gateway, describe the types of non-BACnet equipment/networks(s) that the gateway supports:

Limited Warranty

Limited Warranty

Honeywell Analytics, Inc. warrants to the original purchaser and/or ultimate customer ("Purchaser") of Honeywell products ("Product") that if any part thereof proves to be defective in material or workmanship within one (1) year, such defective part will be repaired or replaced, free of charge, at Honeywell Analytics' discretion if shipped prepaid to Honeywell Analytics in a package equal to or in the original container. The Product will be returned freight prepaid and repaired or replaced if it is determined by Honeywell Analytics that the part failed due to defective materials or workmanship. The repair or replacement of any such defective part shall be Honeywell Analytics' sole and exclusive responsibility and liability under this limited warranty.

Re-Stocking Policy

The following re-stocking fees will apply when customers return products for credit:

15% re-stocking fee will be applied if the product is returned within 1 month following the shipping date

30% re-stocking fee will be applied if the product is returned within 3 months following the shipping date.

A full credit (less re-stocking fee) will only be issued if the product is in perfect working condition. If repairs are required on the returned product, the cost of these repairs will be deducted from the credit to be issued.

No credits will be issued beyond the three month period.

Exclusions

If gas sensors are part of the Product, the gas sensor is covered by a twelve (12) month limited warranty of the manufacturer.

If gas sensors are covered by this limited warranty, the gas sensor is subject to inspection by Honeywell Analytics for extended exposure to excessive gas concentrations if a claim by the Purchaser is made under this limited warranty. Should such inspection indicate that the gas sensor has been expended rather than failed prematurely, this limited warranty shall not apply to the Product.

Limited Warranty

This limited warranty does not cover consumable items, such as batteries, or items subject to wear or periodic replacement, including lamps, fuses, valves, vanes, sensor elements, cartridges, or filter elements.

Warranty Limitation and Exclusion

Honeywell Analytics will have no further obligation under this limited warranty. All warranty obligations of Honeywell Analytics are void if the Product has been subject to abuse, misuse, negligence, or accident or if the Purchaser fails to perform any of the duties set forth in this limited warranty or if the Product has not been operated in accordance with instructions, or if the Product serial number has been removed or altered.

Disclaimer of Unstated Warranties

The warranty printed above is the only warranty applicable to this purchase. All other warranties, express or implied, including, but not limited to, the implied warranties of merchantability or fitness for a particular purpose are hereby disclaimed.

Limitation of Liability

It is understood and agreed that Honeywell Analytics' liability, whether in contract, in tort, under any warranty, in negligence or otherwise shall not exceed the amount of the purchase price paid by the purchaser for the product and under no circumstances shall Honeywell Analytics be liable for special, indirect, or consequential damages. The price stated for the product is a consideration limiting Honeywell Analytics' liability. No action, regardless of form, arising out of the transactions under this warranty may be brought by the purchaser more than one year after the cause of actions has occurred.